

## EXPLOSION PROOF PTZ CAMERA DATA

(UNV 2MP 20×)



### Main features:

- CNEx/ATEX certificated
- Stainless steel 304/316L
- IP68
- 1 cable gland
- 1/2.8" Progressive Scan CMOS
- 1920(H)\*1080(V)@60fps
- H.265,H.265+
- Intelligent variable speed function, PTZ speed automatic adjustment with the depth of field;
- Built-in power converter,no need for additional ex proof power supply box, the real integrative equipment, easy to install and cost savings;
- Built-in OSD menu, friendly interface and easy to operate;
- CVT,Continuously 360° horizontal rotation and vertical  $\pm 90^\circ$  auto-flip;
- Optional accessories: sun shield, lens decoder, window wiper, wiper decoder, auto-heating, auto-cooling modular.

**Camera**

**Description**

Sensor	1/2.8 inch megapixel, progressive scan CMOS
Focal Length/Zoom	5.2~104mm, 20X optical zoom
Zoom/Focus	Motorized zoom, automatic focus
Lens	Auto/manual, F1.5~F3.0
Shutter	Auto/manual, 1/6~1/100000s
WDR	120dB
Min. Illumination	0.002lux(F1.5, AGC ON, Color) 0.0002lux(F1.5, AGC ON, Black/white:)
Day/Night	IR-cut filter with auto switch (ICR)

**Video**

**Description**

Video Compression	H.265、H.264、MJPEG
Frame Rate	1080P (1920*1080) Max 30 fps
Video Streaming	Triple
OSD	Time OSD, Customized OSD
Privacy Mask	Supported

**Storage**

**Description**

Edge Storage	Micro SD, up to 128GB
--------------	-----------------------

**Smart**

**Description**

Behavior Detection	Intrusion, cross line, motion detection, Auto tracking
Exception Detection	Audio exception detection
Recognition	Face detection
Statistical Analysis	People counting

**Network**

**Description**

Protocols	L2TP, IPv4, IGMP, ICMP, ARP, TCP, UDP, DHCP, PPPoE, RTP, RTSP, RTCP, DNS, DDNS, NTP, FTP, UPnP, HTTP, HTTPS, SMTP 802.1x
Compatible Integration	ONVIF、API

**Interface**

**Description**

Interfaces	36-pin FFC, including network interface, power, serial interface and video output interface
Audio I/O	1/ 1
Alarm I/O	1/ 1
Power	12V DC ±25%

General Specifications

Model	FNKZ-PTZ.DY
Explosion level	ExdIICT6 Gb/Ex tD A21 IP68 T80°C
Input Voltage	AC220V±10%
Protection level	IP68 Standard, Surge Protection and Voltage Transient Protection
Material	Stainless steel 304/316L
Working Temperature/Humidity	-40°C ~ +60°C, ≤90%RH
Pan Range	360° continuous
Tilt Range	-90°~+90°
Pan speed	Configurable, from 0.1°/S~45°/S
Tilt speed	Configurable, from 0.1°/S~450/S
Number of Preset	256
Power-off Memory	Support
Park Action	Preset/Pattern Scan/Patrol Scan/Auto Scan/Tilt Scan/Random Scan//Frame Scan/Panorama Scan
PTZ Position Display	ON/OFF
Power Supply	220VAC
Power Consumption	Max:50w
Dimension	350mm(L)×290mm(W)×377.5mm(H)
Weight	27kg
Packing	Carton box with EPE inside (605mm*500mm*305mm)

Dimension

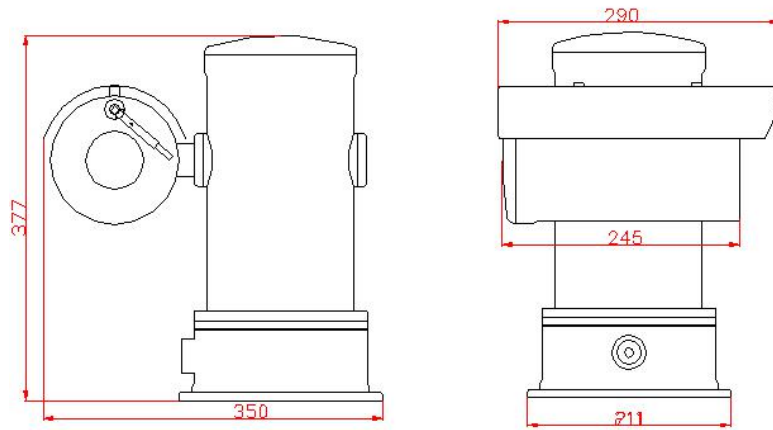

Pack



Accessories



EX-Proof box



flexible pipe