

EXPLOSION PROOF CAMERA DATA

(UNV 2MP 20×)



Main features:

- CNEx/ATEX certificated
- Stainless steel 304/316L
- Surface finish: electropolished or corrosion resistant paint finish
- IP68
- 1 cable gland
- 1/2.8" Progressive Scan CMOS
- 1920(H)*1080(V)@60fps
- H.265,H.265+
- Applicable for the extreme circumstances with explosive gas or dust, like petro-chemical, offshore, marine, oil tank, gas station, onshore sites.
- Optional accessories: sun shield, lens decoder, auto-heating, auto-cooling modular.

Camera Specification

Camera

	Description
Sensor	1/2.8 inch megapixel, progressive scan CMOS
Focal Length/Zoom	5.2~104mm, 20X optical zoom
Zoom/Focus	Motorized zoom, automatic focus
Lens	Auto/manual, F1.5~F3.0
Shutter	Auto/manual, 1/6~1/100000s
WDR	120dB
Min. Illumination	0.002lux(F1.5, AGC ON, Color) 0.0002lux(F1.5, AGC ON, Black/white:)
Day/Night	IR-cut filter with auto switch (ICR)

Video

	Description
Video Compression	H.265、H.264、MJPEG
Frame Rate	1080P (1920*1080) Max 30 fps
Video Streaming	Triple
OSD	Time OSD, Customized OSD
Privacy Mask	Supported

Storage

	Description
Edge Storage	Micro SD, up to 128GB

Smart

	Description
Behavior Detection	Intrusion, cross line, motion detection, Auto tracking
Exception Detection	Audio exception detection
Recognition	Face detection
Statistical Analysis	People counting

Network

	Description
Protocols	L2TP, IPv4, IGMP, ICMP, ARP, TCP, UDP, DHCP, PPPoE, RTP, RTSP, RTCP, DNS, DDNS, NTP, FTP, UPnP, HTTP, HTTPS, SMTP 802.1x
Compatible Integration	ONVIF、API

Interface

	Description
Interfaces	36-pin FFC, including network interface, power, serial interface and video output interface
Audio I/O	1/ 1
Alarm I/O	1/ 1

General Specification

Model	FNKZ-IC.HN
Explosion levels	Ex d IIC T6 Gb/Ex tD A21 IP68 T80°C IP68
Waterproof	IP68
Input Voltage	220VAC±10%
Voltage	DC12V/AC220V/PoE(802.3af)(Class 0)
Current	≤2A
Power Consumption	≤8W
Installation	Outdoor
Operation Temperature	-20°C ~ +60°C
Operation Humidity	≤90%RH
Dimension	350mm(L)×280mm(W)×150mm(H)
Day& Night:	IR cut filter with auto switch
Weight	10kg
Window	Two-sized coating tempered glass
Packing	Carton box with EPE inside
Packing size	510mm(L)×400mm(W)×255mm(H)

Dimension

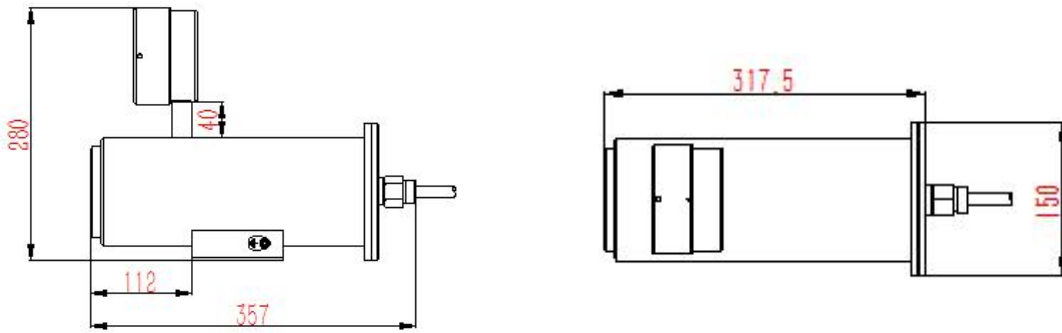

Pack



Accessories



EX-Proof box



flexible pipe