

EXPLOSION PROOF CAMERA DATA

(UNV 2MP 30×)



Main features:

- CNEx/ATEX certificated
- Stainless steel 304/316L
- Surface finish: electropolished or corrosion resistant paint finish
- IP68
- 1 cable gland
- 1/2.8" Progressive Scan CMOS
- 1920(H)*1080(V)@60fps
- H.265,H.265+
- Applicable for the extreme circumstances with explosive gas or dust, like petro-chemical, offshore, marine, oil tank, gas station, onshore sites.
- Optional accessories: sun shield, lens decoder, auto-heating, auto-cooling modular.

Camera Specification

Camera

Description

Sensor	1/2.8", 2 megapixel, progressive scan CMOS
Focal Length/Zoom	4.5~135mm, 30x optical zoom
Zoom/Focus	Motorized zoom, automatic focus
Lens	Auto/manual, F1.6~F4.4
Shutter	Auto/manual, 1/6~1/100000 s
WDR	120dB
Min. Illumination	Color: 0.002 lux (F1.6, AGC ON) Black/white: 0.0002 lux (F1.6, AGC ON)
Day/Night	IR-cut filter with auto switch (ICR)

Video

Description

Max. Resolution	1920 × 1080
Video Compression	H.265, H.264, MJPEG
Frame Rate	1080P (1920×1080):Max 60 fps
Video Streaming	Triple
OSD	Up to 8 OSDs

Storage

Description

Edge Storage	Micro SD, up to 128GB
--------------	-----------------------

Network

Description

Protocols	L2TP, IPv4, IGMP, ICMP, ARP, TCP, UDP, DHCP, PPPoE, RTP, RTSP, RTCP, DNS, DDNS, NTP, FTP, UPnP, HTTP, HTTPS, SMTP 802.1x
Compatible Integration	ONVIF、API

Interface

Description

Interfaces	36-pin FFC, including network interface, power, serial interface and video output interface
Audio I/O	1/ 1
Alarm I/O	1/ 1

General Specification

Model	FNKZ-IC.HN
Explosion levels	Ex d IIC T6 Gb/Ex tD A21 IP68 T80°C IP68
Waterproof	IP68
Input Voltage	220VAC±10%
Voltage	DC12V/AC220V/PoE(802.3af)(Class 0)
Current	≤2A
Power Consumption	≤8W
Installation	Outdoor
Operation Temperature	-20°C ~ +60°C
Operation Humidity	≤90%RH
Dimension	350mm(L)×280mm(W)×150mm(H)
Day& Night:	IR cut filter with auto switch
Weight	10kg
Window	Two-sized coating tempered glass
Packing	Carton box with EPE inside
Packing size	510mm(L)×400mm(W)×255mm(H)

Dimension

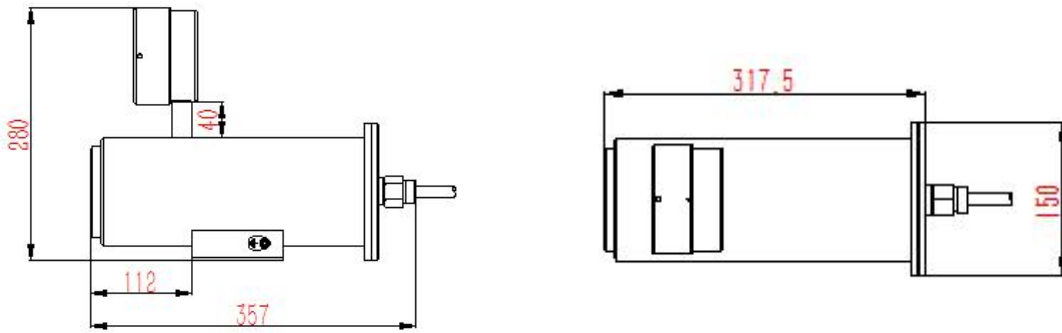

Pack



Accessories



EX-Proof box



flexible pipe