

EXPLOSION PROOF CAMERA DATA

(DH 2MP 23×)



Main features:

- CNEx/ATEX certificated
- Stainless steel 304/316L
- Surface finish: electropolished or corrosion resistant paint finish
- IP68
- 1 cable gland
- 1/2.8" Progressive Scan CMOS
- 1920(H)*1080(V)@60fps
- H.265,H.265+
- Applicable for the extreme circumstances with explosive gas or dust, like petro-chemical, offshore, marine, oil tank, gas station, onshore sites.
- Optional accessories: sun shield, lens decoder, auto-heating, auto-cooling modular.

Camera Specification

Camera

Max. Image Resolution :	1920*1080
Image Sensor:	1/2.8 Progressive Scan CMOS
Min. Illumination: Color:	0.005 lux@F1.6 B/W: 0.0005 lux @F1.6
Shutter Speed:	1/1-1/30000s
Day & Night:	IR cut filter with auto switch
White Balance:	Auto/Manual/ATW(Auto-Tracking White Balance) /Indoor/ Outdoor/ Fluorescent Lamp/Sodium Lamp
AGC(Auto Gain Control):	Auto/Manual
BLC(Back Light Compensation):	Support
HLC(High Light Compensation):	Support
Smart Defog:	Support
WDR:	≥55dB
Digital Zoom:	16
Auto Focus:	Auto/Semi-automatic/Manual

Lens

Focal Length:	5.5mm-126.5mm 23× optical zoom
Zoom Speed:	approx. 3.5s
Field of View:	vertical 51°-2.6°(Wide-tele)
Minimum Working Distance:	100mm-1000mm
Aperture Range:	F1.6-F3.5

Alarm

Alarm Input:	1
Alarm Output:	1

Network

Main Stream:	50Hz:25fps (1920*1080), 50fps(1920*1080), 25fps(1280*960), 25fps(1280*720), 60Hz:30fps (1920*1080), 60fps(1920*1080), 30fps(1280*960), 30fps(1280*720),
Sub Stream:	50Hz:25fps (704*576), 25fps(352*288), 60Hz:25fps(704*480), 25fps(352*240)
Third Stream:	50Hz:25fps (1920*1080), 25fps(1280*960), 25fps(1280*720), 60Hz:30fps (1920*1080), 30fps(1280*960), 30fps(1280*720)
Video Compression:	H.265/H.264 Base line Profile/H.264 Main profile/H.264 High Profile/M-JPEG
Auto Compression:	G.711a/G.711 Mu/AAC/G.722/G.726/MPEG2-L2
Protocols:	IPv4/IPv6,HTTPS,802.1x,Qos,FTP,SMTP,UPnP,SNMP,DNS,DDNS,NTP,RTSP,RTP,TCP,UDP,IGMP,ICMP,DHCP,PPPoE
User/Host:	Up to 20 users
Security Measures:	User Authentication(User ID and Password), Host Authentication(MAC Address), HTTPS Encryption,IEEE802.1x Port-Based Network Access Control
Communication interface:	PELCOB/PELCOP Protocol,DH-SD1 Protocol,SONYVISCA Protocol
External Control:	RS485; Bit Rate 9600,19200,38400bps, VISCA232, Bit Rate fixed at 9600

General Specification

Model	FNKZ-IC.HN
Explosion levels	Ex d IIC T6 Gb/Ex tD A21 IP68 T80°C IP68
Waterproof	IP68
Input Voltage	220VAC±10%
Voltage	DC12V/AC220V/PoE(802.3af)(Class 0)
Current	≤2A
Power Consumption	≤8W
Installation	Outdoor
Operation Temperature	-20°C ~ +60°C
Operation Humidity	≤90%RH
Dimension	350mm(L)×280mm(W)×150mm(H)
Day& Night:	IR cut filter with auto switch
Weight	10kg
Window	Two-sized coating tempered glass
Packing	Carton box with EPE inside
Packing size	510mm(L)×400mm(W)×255mm(H)

Dimension

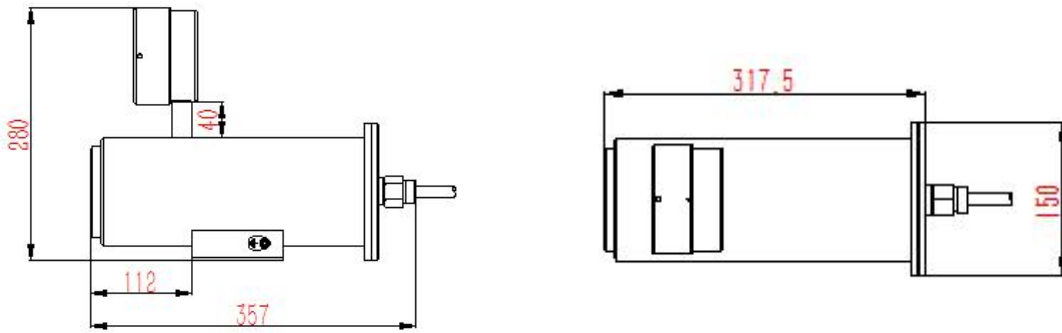

Pack



Accessories



EX-Proof box



flexible pipe