

EXPLOSION PROOF THERMAL PTZ CAMERA DATA

(UNV 2MP 20×)



Main features:

- CNEEx certified, IP68
- Stainless steel 304/316L
- Surface finish: electropolished or corrosion resistant paint finish
- Built-in video compression coding, easy for network transmission powerful IDE image detail enhancement algorithm
- Intelligent high-temperature pre-alarming with various adjustable grades, higher detection efficiency, less misinformation
- Embedded intelligent analysis supports motion detection, line crossing detection, regional entry/exit detection, and intelligent PTZ tracking
- Professional photoelectric zooming technology
- AGC(automatic gain stability), 3D noise reduction, IDE (image details enhancement algorithm)
- Double serial communication: RS-232*1, R-485*1
- Application Scenario: It is mainly applicable in scenarios of zero visibility and strong light source interference, such as airport, harbor, tourism area, perimeter, oilfield, military, key fields

Camera Specification

Camera

Description

Sensor	1/2.8 inch megapixel, progressive scan CMOS
Focal Length/Zoom	5.2~104mm, 20X optical zoom
Zoom/Focus	Motorized zoom, automatic focus
Lens	Auto/manual, F1.5~F3.0
Shutter	Auto/manual, 1/6~1/100000s
WDR	120dB
Min. Illumination	0.002lux(F1.5, AGC ON, Color) 0.0002lux(F1.5, AGC ON, Black/white:)
Day/Night	IR-cut filter with auto switch (ICR)

Video

Description

Video Compression	H.265、H.264、MJPEG
Frame Rate	1080P (1920*1080) Max 30 fps
Video Streaming	Triple
OSD	Time OSD, Customized OSD
Privacy Mask	Supported

Storage

Description

Edge Storage	Micro SD, up to 128GB
--------------	-----------------------

Smart

Description

Behavior Detection	Intrusion, cross line, motion detection, Auto tracking
Exception Detection	Audio exception detection
Recognition	Face detection
Statistical Analysis	People counting

Network

Description

Protocols	L2TP, IPv4, IGMP, ICMP, ARP, TCP, UDP, DHCP, PPPoE, RTP, RTSP, RTCP, DNS, DDNS, NTP, FTP, UPnP, HTTP, HTTPS, SMTP 802.1x
Compatible Integration	ONVIF、API

Interface

Description

Interfaces	36-pin FFC, including network interface, power, serial interface and video output interface
Audio I/O	1/ 1
Alarm I/O	1/ 1
Power	12V DC ±25%

Item	384×288	640×480
Detector Data		
Material	aSi	
IR resolution	384×288	640×480
Pixel pitch	17μm	
Spectral range	7.5~14μm	
NETD/Sensitivity	≤70mK	≤60mK
Lens Data		
Lens(optional)	35mm、50mm、75mm athermal lens, 100mm、150mm motorized lens, 25~100mm、30~150mm、25~225mm continuous zoom lens、60/150mm dual FOV lens(other lens are optional)	
Image Performance		
Image enhancement	IVE image enhancement algorithm	
Frequency	50Hz	
Amplification	2X, 4X	
Polarity/LUT mode	Black hot/White hot	
Startup time	3s	
Image gain	Auto/Manual	
Focusing	Motor	
Cross cursor	ON/OFF	
Image frozen	Yes	
Interface		
Primary electrical	40pin	
Control	RS232	
Analog video output	PAL	
Digital video output	Cameralink、LVCMOS optional	
Keypad	4 button keyboard	
Power System		
Working voltage	DC: +4V~+5.5V(Standard: 5V)	
Power consumption	1.5W	1.25W
Reverse polarity	Yes	
Over&Under voltage	Yes	

General Specifications

Model	FNKZ-PTZ.ST
Explosion level	ExdIICT6 Gb/Ex tD A21 IP68 T80°C
Input Voltage	AC220V±10%
Protection level	IP68 Standard, Surge Protection and Voltage Transient Protection
Material	SUS304/316L
Working Temperature/Humidity	-20°C ~ +60°C, ≤90%RH
Pan Range	360° continuous
Tilt Range	-90°~+90°
Pan speed	Configurable, from 0.1°/S~300°/S
Tilt speed	Configurable, from 0.1°/S~240°/S
Number of Preset	256
Power-off Memory	Support
Park Action	Preset/Pattern Scan/Patrol Scan/Auto Scan/Tilt Scan/Random Scan//Frame Scan/Panorama Scan
PTZ Position Display	ON/OFF
Power Supply	220VAC
Power Consumption	Max:40w
Dimension	420mm(L)×238mm(W)×378mm(H)
Weight	35kg
Packing	Carton box with EPE inside (605mm*500mm*305mm)

Dimension

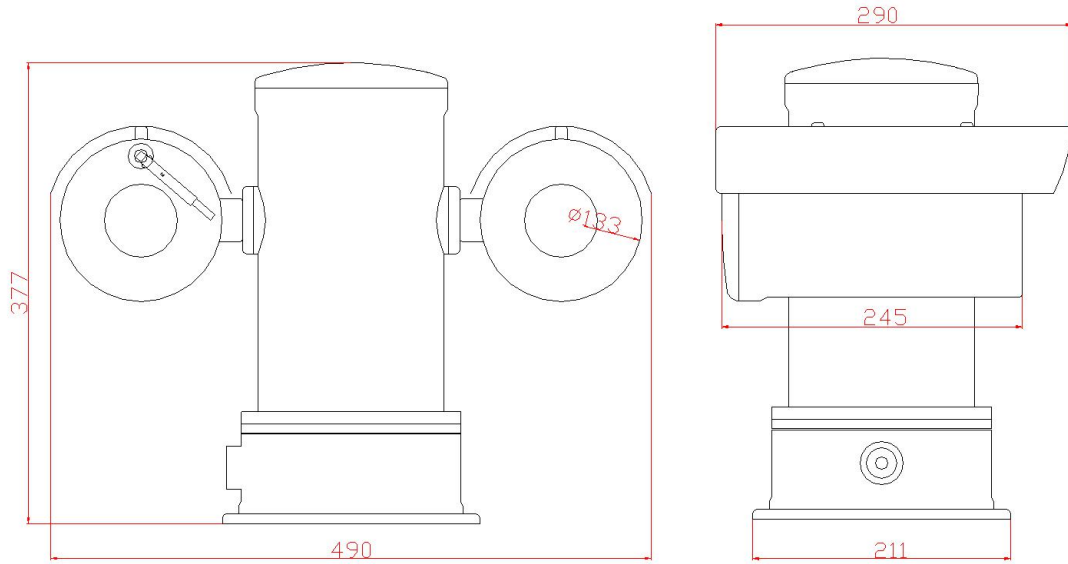

Pack



Accessories



EX-Proof box



flexible pipe