

EXPLOSION PROOF THERMAL PTZ CAMERA DATA

(DH 2MP 23×)



Main features:

- CNEEx certified, IP68
- Stainless steel 304/316L
- Surface finish: electropolished or corrosion resistant paint finish
- Built-in video compression coding, easy for network transmission powerful IDE image detail enhancement algorithm
- Intelligent high-temperature pre-alarming with various adjustable grades, higher detection efficiency, less misinformation
- Embedded intelligent analysis supports motion detection, line crossing detection, regional entry/exit detection, and intelligent PTZ tracking
- Professional photoelectric zooming technology
- AGC(automatic gain stability), 3D noise reduction, IDE (image details enhancement algorithm)
- Double serial communication: RS-232*1, R-485*1
- Application Scenario: It is mainly applicable in scenarios of zero visibility and strong light source interference, such as airport, harbor, tourism area, perimeter, oilfield, military, key fields

Camera Specification

Max. Image Resolution :	1920*1080
Image Sensor:	1/2.8 Progressive Scan CMOS
Min. Illumination: Color:	0.005 lux@F1.6 B/W: 0.0005 lux @F1.6
Shutter Speed:	1/1-1/30000s
Day & Night:	IR cut filter with auto switch
White Balance:	Auto/Manual/ATW(Auto-Tracking White Balance) /Indoor/ Outdoor/ Fluorescent Lamp/Sodium Lamp
AGC(Auto Gain Control):	Auto/Manual
BLC(Back Light Compensation):	Support
HLC(High Light Compensation):	Support
Smart Defog:	Support
WDR:	≥55dB
Digital Zoom:	16
Auto Focus:	Auto/Semi-automatic/Manual
Lens	
Focal Length:	5.5mm-126.5mm 23× optical zoom
Zoom Speed:	approx. 3.5s
Field of View:	vertical 51°-2.6°(Wide-tele)
Minimum Working Distance:	100mm-1000mm
Aperture Range:	F1.6-F3.5
Alarm	
Alarm Input:	1
Alarm Output:	1
Network	
Main Stream:	50Hz:25fps (1920*1080), 50fps(1920*1080), 25fps(1280*960), 50fps(1280*960) , 25fps(1280*720), 50fps(1280*720)
Sub Stream:	50Hz:25fps (704*576), 25fps(352*288), 60Hz:25fps(704*480), 25fps(352*240)
Third Stream:	50Hz:25fps (1920*1080), 25fps(1280*960), 25fps(1280*720), 25fps(704*576), 25fps(352*288)
Video Compression:	60Hz:30fps (1920*1080), 30fps(1280*960), 30fps(1280*720), 30fps(704*480), 25fps(352*240)
Auto Compression:	H.265/H.264 Base line Profile/H.264 Main profile/H.264 High Profile/M-JPEG
	G.711a/G.711 Mu/AAC/G.722/G.726/MPEG2-L2

Protocols:	IPv4/IPv6,HTTPS,802.1x,Qos,FTP,SMTP,UPnP,SNMP,DNS,DDNS,NTP,RTSP,RTP,TCP,UDP,IGMP,ICMP,DHCP,PPPoE
User/Host:	Up to 20 users
Security Measures:	User Authentication(User ID and Password), Host Authentication(MAC Address), HTTPS Encryption,IEEE802.1x Port-Based Network Access Control
Communication interface:	PELCOD/PELCOP Protocol,DH-SD1 Protocol,SONYVISCA Protocol
External Control:	RS485; Bit Rate 9600,19200,38400bps, VISCA232, Bit Rate fixed at 9600

Item	384×288	640×480
Detector Data		
Material	aSi	
IR resolution	384×288	640×480
Pixel pitch	17μm	
Spectral range	7.5~14μm	
NETD/Sensitivity	≤70mK	≤60mK
Lens Data		
Lens(optional)	35mm、50mm、75mm athermal lens, 100mm、150mm motorized lens, 25~100mm、30~150mm、25~225mm continuous zoom lens、60/150mm dual FOV lens(other lens are optional)	
Image Performance		
Image enhancement	IVE image enhancement algorithm	
Frequency	50Hz	
Amplification	2X, 4X	
Polarity/LUT mode	Black hot/White hot	
Startup time	3s	
Image gain	Auto/Manual	
Focusing	Motor	
Cross cursor	ON/OFF	
Image frozen	Yes	
Interface		
Primary electrical	40pin	
Control	RS232	
Analog video output	PAL	
Digital video output	Cameralink、LVCMOS optional	
Keypad	4 button keyboard	
Power System		
Working voltage	DC: +4V~+5.5V(Standard: 5V)	
Power consumption	1.5W	1.25W
Reverse polarity	Yes	
Over&Under voltage	Yes	

General Specifications

Model	FNKZ-PTZ.ST
Explosion level	ExdIICT6 Gb/Ex tD A21 IP68 T80°C
Input Voltage	AC220V±10%
Protection level	IP68 Standard, Surge Protection and Voltage Transient Protection
Material	SUS304/316L
Working Temperature/Humidity	-20°C ~ +60°C, ≤90%RH
Pan Range	360° continuous
Tilt Range	-90°~+90°
Pan speed	Configurable, from 0.1°/S~300°/S
Tilt speed	Configurable, from 0.1°/S~240°/S
Number of Preset	256
Power-off Memory	Support
Park Action	Preset/Pattern Scan/Patrol Scan/Auto Scan/Tilt Scan/Random Scan//Frame Scan/Panorama Scan
PTZ Position Display	ON/OFF
Power Supply	220VAC
Power Consumption	Max:40w
Dimension	420mm(L)×238mm(W)×378mm(H)
Weight	35kg
Packing	Carton box with EPE inside (605mm*500mm*305mm)

Dimension

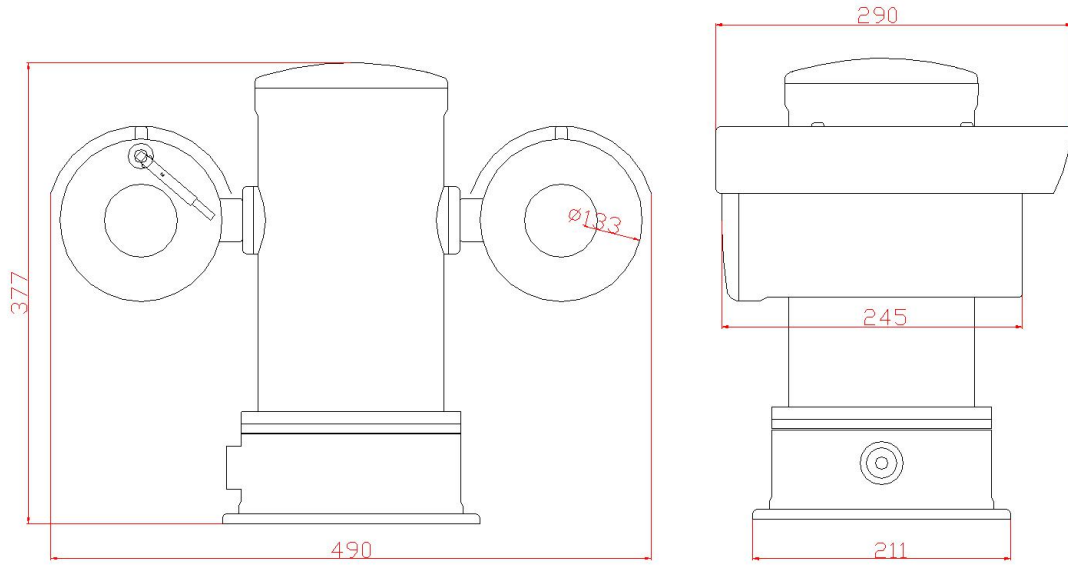

Pack



Accessories



EX-Proof box



flexible pipe