

EXPLOSION PROOF PTZ CAMERA DATA

(UNV 2MP 20×)



Main features:

- CNEEx/ATEX certificated
- Stainless steel 304/316L
- IP68
- 1 cable gland
- H.265,H.265+
- Intelligent variable speed function, PTZ speed automatic adjustment with the depth of field;
- Built-in power converter,no need for additional ex proof power supply box, the real integrative equipment, easy to install and cost savings;
- Built-in OSD menu, friendly interface and easy to operate;
- CVT,Continuously 360° horizontal rotation and vertical $\pm 90^{\circ}$ auto-flip;
- Optional accessories: sun shield, lens decoder, window wiper, wiper decoder, auto-heating, auto-cooling modular.

Camera Specification

Camera	Description
Sensor	1/2.8 inch megapixel, progressive scan CMOS
Focal Length/Zoom	5.2~104mm, 20X optical zoom
Zoom/Focus	Motorized zoom, automatic focus
Lens	Auto/manual, F1.5~F3.0
Shutter	Auto/manual, 1/6~1/100000s
WDR	120dB
Min. Illumination	0.002lux(F1.5, AGC ON, Color) 0.0002lux(F1.5, AGC ON, Black/white:)
Day/Night	IR-cut filter with auto switch (ICR)
Video	Description
Video Compression	H.265、H.264、MJPEG
Frame Rate	1080P (1920*1080) Max 30 fps
Video Streaming	Triple
OSD	Time OSD, Customized OSD
Privacy Mask	Supported
Storage	Description
Edge Storage	Micro SD, up to 128GB
Smart	Description
Behavior Detection	Intrusion, cross line, motion detection, Auto tracking
Exception Detection	Audio exception detection
Recognition	Face detection
Statistical Analysis	People counting
Network	Description
Protocols	L2TP, IPv4, IGMP, ICMP, ARP, TCP, UDP, DHCP, PPPoE, RTP, RTSP, RTCP, DNS, DDNS, NTP, FTP, UPnP, HTTP, HTTPS, SMTP 802.1x
Compatible Integration	ONVIF、API
Interface	Description
Interfaces	36-pin FFC, including network interface, power, serial interface and video output interface
Audio I/O	1/ 1
Alarm I/O	1/ 1
Power	12V DC ±25%

General Specifications

Model	FNKZ-PTZ.ST
Explosion level	ExdIICT6 Gb/Ex tD A21 IP68 T80°C
Input Voltage	AC220V±10%
Protection level	IP68 Standard, Surge Protection and Voltage Transient Protection
Material	SUS304/316L
Working Temperature/Humidity	-20°C ~ +60°C, ≤90%RH
Pan Range	360° continuous
Tilt Range	-90° ~ +90°
Pan speed	Configurable, from 0.1°/S~300°/S
Tilt speed	Configurable, from 0.1°/S~240°/S
Number of Preset	256
Power-off Memory	Support
Park Action	Preset/Pattern Scan/Patrol Scan/Auto Scan/Tilt Scan/Random Scan//Frame Scan/Panorama Scan
PTZ Position Display	ON/OFF
Power Supply	220VAC
Power Consumption	Max:40w
Dimension	420mm(L)×238mm(W)×378mm(H)
Weight	35kg
Packing	Carton box with EPE inside (605mm*500mm*305mm)

Dimension

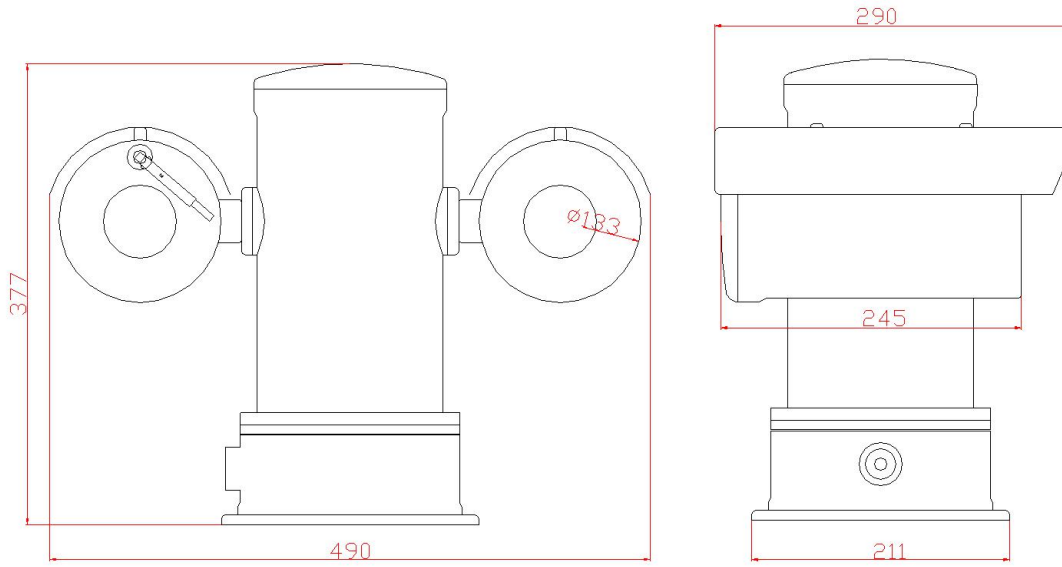

Pack



Accessories



EX-Proof box



flexible pipe