

EXPLOSION PROOF PTZ CAMERA DATA

(UNV 2MP 30×)



Main features:

- CNEx/ATEX certificated
- Stainless steel 304/316L
- IP68
- 1 cable gland
- H.265,H.265+
- Intelligent variable speed function, PTZ speed automatic adjustment with the depth of field;
- Built-in power converter,no need for additional ex proof power supply box, the real integrative equipment, easy to install and cost savings;
- Built-in OSD menu, friendly interface and easy to operate;
- CVT,Continuously 360° horizontal rotation and vertical $\pm 90^\circ$ auto-flip;
- Optional accessories: sun shield, lens decoder, window wiper, wiper decoder, auto-heating, auto-cooling modular.

Camera Specification

Camera	Description
Sensor	1/2.8", 2 megapixel, progressive scan CMOS
Focal Length/Zoom	4.5~135mm, 30x optical zoom
Zoom/Focus	Motorized zoom, automatic focus
Lens	Auto/manual, F1.6~F4.4
Shutter	Auto/manual, 1/6~1/100000 s
WDR	120dB
Min. Illumination	Color: 0.002 lux (F1.6, AGC ON) Black/white: 0.0002 lux (F1.6, AGC ON)
Day/Night	IR-cut filter with auto switch (ICR)
Video	Description
Max. Resolution	1920 × 1080
Video Compression	H.265, H.264, MJPEG
Frame Rate	1080P (1920×1080):Max 60 fps
Video Streaming	Triple
OSD	Up to 8 OSDs
Storage	Description
Edge Storage	Micro SD, up to 128GB
Network	Description
Protocols	L2TP, IPv4, IGMP, ICMP, ARP, TCP, UDP, DHCP, PPPoE, RTP, RTSP, RTCP, DNS, DDNS, NTP, FTP, UPnP, HTTP, HTTPS, SMTP 802.1x
Compatible Integration	ONVIF、API
Interface	Description
Interfaces	36-pin FFC, including network interface, power, serial interface and video output interface
Audio I/O	1/ 1
Alarm I/O	1/ 1
General	Description
Power	12V DC ±25% Power consumption: 4.5 W
Dimensions (W x D x H)	96.6 mm x 50 mm x 60 mm (3.8" x 2.0" x 2.4")
Weight	0.27 kg (0.6lb)

General Specifications

Model	FNKZ-PTZ.ST
Explosion level	ExdIICT6 Gb/Ex tD A21 IP68 T80°C
Input Voltage	AC220V±10%
Protection level	IP68 Standard, Surge Protection and Voltage Transient Protection
Material	SUS304/316L
Working Temperature/Humidity	-20°C ~ +60°C, ≤90%RH
Pan Range	360° continuous
Tilt Range	-90° ~ +90°
Pan speed	Configurable, from 0.1°/S~300°/S
Tilt speed	Configurable, from 0.1°/S~240°/S
Number of Preset	256
Power-off Memory	Support
Park Action	Preset/Pattern Scan/Patrol Scan/Auto Scan/Tilt Scan/Random Scan//Frame Scan/Panorama Scan
PTZ Position Display	ON/OFF
Power Supply	220VAC
Power Consumption	Max:40w
Dimension	420mm(L)×238mm(W)×378mm(H)
Weight	35kg
Packing	Carton box with EPE inside (605mm*500mm*305mm)

Dimension

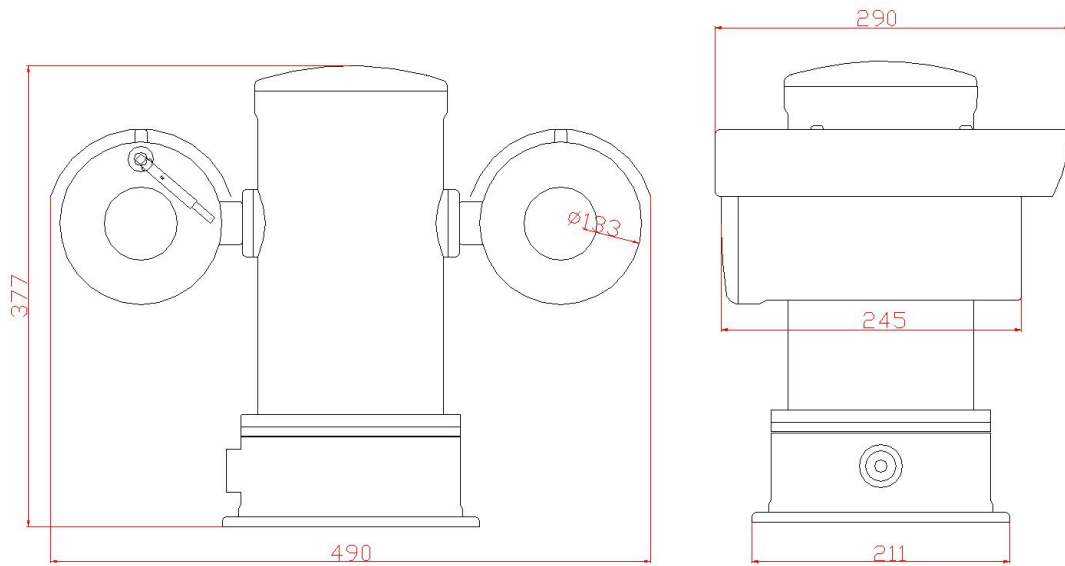

Pack



Accessories



EX-Proof box



flexible pipe