

EXPLOSION PROOF PTZ CAMERA DATA

(DH 4MP 30×)



Main features:

- CNEx/ATEX certificated
- Stainless steel 304/316L
- IP68
- 1 cable gland
- H.265,H.265+
- Intelligent variable speed function, PTZ speed automatic adjustment with the depth of field;
- Built-in power converter,no need for additional ex proof power supply box, the real integrative equipment, easy to install and cost savings;
- Built-in OSD menu, friendly interface and easy to operate;
- CVT,Continuously 360° horizontal rotation and vertical $\pm 90^\circ$ auto-flip;
- Optional accessories: sun shield, lens decoder, window wiper, wiper decoder, auto-heating, auto-cooling modular.

Camera Specification

Camera

Max. Image Resolution :	2592*1520
Image Sensor:	1/3 " Progressive Scan CMOS
Shutter Speed:	1/1-1/30000s
Day & Night:	IR cut filter with auto switch
White Balance:	Auto/Manual/ATW(Auto-Tracking White Balance) /Indoor/ Outdoor/ Fluorescent Lamp/Sodium Lamp
AGC(Auto Gain Control):	Auto/Manual
BLC(Back Light Compensation):	Support
HLC(High Light Compensation):	Support
Smart Defog:	Support
WDR:	≥55dB
Digital Zoom:	16
Auto Focus:	Auto/Semi-automatic/Manual

Lens

Focal Length:	4.5mm-135mm 30× optical zoom
Zoom Speed:	approx. 4s
Field of View:	vertical 59.8°-2.34°(Wide-tele)
Minimum Working Distance:	1000mm-1500mm
Aperture Range:	F1.6-F4.4

Alarm

Alarm Input:	1 (0~5V DC)
Alarm Output:	1

Network

Main Stream:	50Hz: 25fps (2592×1520) 、25fps (2048×1536) 、25fps (1920×1080) 、50fps (1920×1080) 、25fps (1280×960) 、25fps (1280×720)
Sub Stream:	60Hz: 30fps (2592×1520) 、30fps (2048×1536) 、30fps (1920×1080) 、60fps (1920×1080) 、30fps (1280×960) 、30fps (1280×720)
Third Stream:	50Hz:25fps(704×576)、25fps(352×288) 60Hz:30fps(704×480)、30fps(352×240) 50Hz:25fps (2592×1520) 、25fps (1920×1080) 、25fps (1280×960) 、25fps (1280×720)
Video Compression:	60Hz:30fps (2592×1520) 、30fps (1920×1080) 、30fps (1280×960) 、30fps (1280×720)
Auto Compression:	H.265; H.264BaselineProfile; H.264MainProfile; H.264HighProfile; MJPEG; smart H.265; smart H.264
Protocols:	G.711A; G.711Mu; AAC; G.722.1; G.726; MPEG2-Layer2; G.729 IPv4; IPv6; HTTP; HTTPS; 802.1x; Qos; FTP; SMTP; UPnP; SNMP; DNS; DDNS; NTP; RTSP; RTP; TCP; UDP; IGMP; ICMP; DHCP; PPPoE
User/Host:	Up to 20 users

Security Measures:	User Authentication(User ID and Password), Host Authentication(MAC Address), HTTPS Encryption,IEEE802.1x Port-Based Network Access Control
Communication interface:	PELCO/PELCO Protocol,DH-SD1 Protocol,SONYVISCA Protocol
External Control:	RS485; Bit Rate 9600,19200,38400bps, VISCA232, Bit Rate fixed at 9600

General Specifications

Model	FNKZ-PTZ.ST
Explosion level	ExdIICT6 Gb/Ex tD A21 IP68 T80°C
Input Voltage	AC220V±10%
Protection level	IP68 Standard, Surge Protection and Voltage Transient Protection
Material	SUS304/316L
Working Temperature/Humidity	-20°C ~ +60°C, ≤90%RH
Pan Range	360° continuous
Tilt Range	-90°~+90°
Pan speed	Configurable, from 0.1°/S~300°/S
Tilt speed	Configurable, from 0.1°/S~240°/S
Number of Preset	256
Power-off Memory	Support
Park Action	Preset/Pattern Scan/Patrol Scan/Auto Scan/Tilt Scan/Random Scan//Frame Scan/Panorama Scan
PTZ Position Display	ON/OFF
Power Supply	220VAC
Power Consumption	Max:40w
Dimension	420mm(L)×238mm(W)×378mm(H)
Weight	35kg
Packing	Carton box with EPE inside (605mm*500mm*305mm)

Dimension

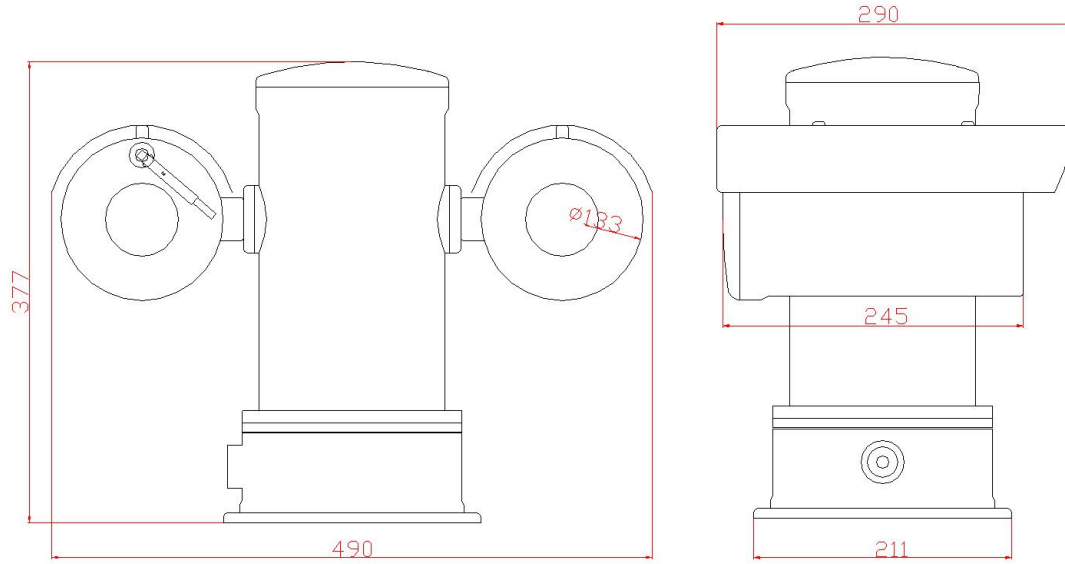

Pack



Accessories



EX-Proof box



flexible pipe