

## EXPLOSION PROOF PTZ CAMERA DATA

(XM 2MP 30×)



### Main features:

- CNEx/ATEX certificated
- Stainless steel 304/316L
- IP68
- 1 cable gland
- 1/2.8" Progressive Scan CMOS
- 1920(H)\*1080(V)@60fps
- H.265,H.265+
- Intelligent variable speed function, PTZ speed automatic adjustment with the depth of field;
- Built-in power converter,no need for additional ex proof power supply box, the real integrative equipment, easy to install and cost savings;
- Built-in OSD menu, friendly interface and easy to operate;
- CVT,Continuously 360° horizontal rotation and vertical  $\pm 90^\circ$  auto-flip;
- Optional accessories: sun shield, lens decoder, auto-heating, auto-cooling modular.

Camera Specification

Max. Image Resolution :	1920*1080
Image Sensor:	1/2.8 Progressive Scan CMOS
Min. Illumination: Color:	0.001 lux@F1.5 B/W: 0.0001 lux @F1.5
Shutter Speed:	1/1-1/30000s
Day & Night:	IR cut filter with auto switch
White Balance:	Auto/Manual/ATW(Auto-Tracking White Balance) /Indoor/ Outdoor/ Fluorescent Lamp/Sodium Lamp
AGC(Auto Gain Control):	Auto/Manual
BLC(Back Light Compensation):	Support
HLC(High Light Compensation):	Support
Smart Defog:	Support
WDR:	≥55dB
Digital Zoom:	16
Auto Focus:	Auto/Semi-automatic/Manual
Lens	
Focal Length:	6mm-180mm 30× optical zoom
Zoom Speed:	approx. 3.5s
Field of View:	Vertical61.2°-2.32°(Wide-tele)
Minimum Working Distance:	10mm-1500mm
Aperture Range:	F1.5-F4.3
Alarm	
Alarm Input:	1
Alarm Output:	1
Network	
Main Stream:	50Hz:25fps (1920*1080), 50fps(1920*1080), 25fps(1280*960), 50fps(1280*960) , 25fps(1280*720), 50fps(1280*720)
Sub Stream:	50Hz:25fps (704*576), 25fps(352*288), 60Hz:25fps(704*480), 25fps(352*240)
Third Stream:	50Hz:25fps (1920*1080), 25fps(1280*960), 25fps(1280*720), 25fps(704*576), 25fps(352*288)
Video Compression:	60Hz:30fps (1920*1080), 30fps(1280*960), 30fps(1280*720), 30fps(704*480), 25fps(352*240)
Auto Compression:	H.265/H.264 Base line Profile/H.264 Main profile/H.264 High Profile/M-JPEG
	G.711a/G.711 Mu/AAC/G.722/G.726/MPEG2-L2

Protocols:	IPv4/IPv6,HTTPS,802.1x,Qos,FTP,SMTP,UPnP,SNMP,DNS,DDNS,NTP,RTSP,RTP,TCP,UDP,IGMP,ICMP,DHCP,PPPoE
User/Host:	Up to 20 users
Security Measures:	User Authentication(User ID and Password), Host Authentication(MAC Address), HTTPS Encryption,IEEE802.1x Port-Based Network Access Control
Communication interface:	PELCOB/PELCOA Protocol,DH-SD1 Protocol,SONYVISCA Protocol
External Control:	RS485; Bit Rate 9600,19200,38400bps, VISCA232, Bit Rate fixed at 9600

#### General Specifications

Model	FNKZ-PTZ.DH
Explosion level	ExdIICT6 Gb/Ex tD A21 IP68 T80°C
Input Voltage	AC220V±10%
Protection level	IP68 Standard, Surge Protection and Voltage Transient Protection
Material	Stainless steel 304/316L
Working Temperature/Humidity	-40°C ~ +60°C, ≤90%RH
Pan Range	360° continuous
Tilt Range	-90°~+90°
Pan speed	Configurable, from 0.1°/S~45°/S
Tilt speed	Configurable, from 0.1°/S~450/S
Number of Preset	256
Power-off Memory	Support
Park Action	Preset/Pattern Scan/Patrol Scan/Auto Scan/Tilt Scan/Random Scan//Frame Scan/Panorama Scan
PTZ Position Display	ON/OFF
Power Supply	220VAC
Power Consumption	Max:50w
Dimension	350mm(L)×290mm(W)×377.5mm(H)
Weight	27kg
Packing	Carton box with EPE inside (605mm*500mm*305mm)

Dimension

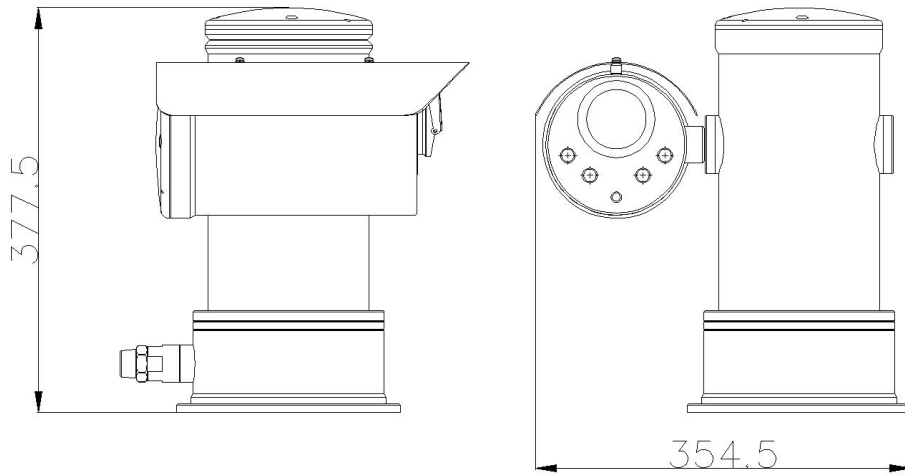

Pack



Accessories



EX-Proof box



flexible pipe